

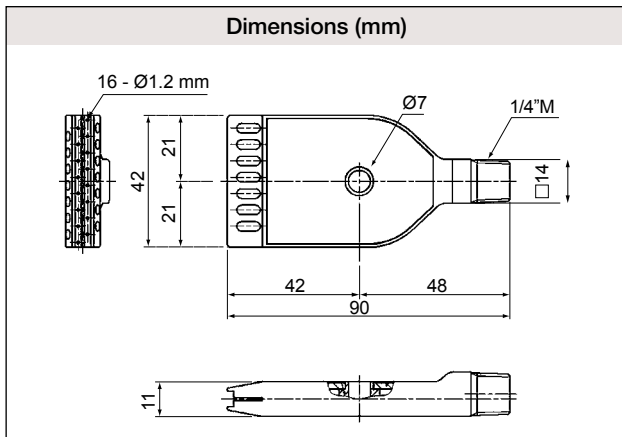

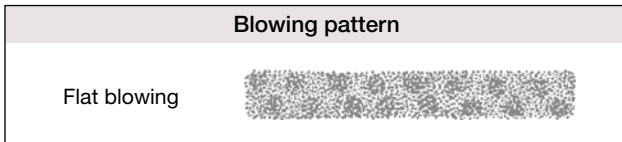









- Air booster nozzle suitable for applications where a flat laminar blow is required. High blowing power through its 16 orifices with a free passage diameter of 1.2, which generate an effective flat blow.
- It presents a considerable reduction in energy expenditure by doubling its blowing power due to its innovative design.
- Uniform distribution of the blow in multi-nozzle assemblies thanks to its interior design.
- Robust and innovative design.
- **In addition to its high effectiveness, it presents a very low noise level. (The human ear interprets a reduction of noise by 10 dB(A) as 50% less noise.)**
- Its multi-orifice design prevents clogging, not exceeding 2.1 bar of static pressure, according to safety regulations.
- Made of injected S316L stainless steel that provides high resistance to mechanical, chemical and high temperature aggressions.
- Suitable for environments where hygiene is crucial.



 Material S316L	 Pressure 1 MPa ca. 10 bar	 Maximum temperature 400 °C
 Thread connection 1/4" male	 Weight 144 g	 Strength of blowing* 8.4 N
 Air consumption* 925 l/min, Normal	 Level of noise* 86 dB(A)	 Product code 1 2 3 1/4M TF-F 42-16-012 S316L-IN

* at 0.5 MPa (ca. 5 bar)

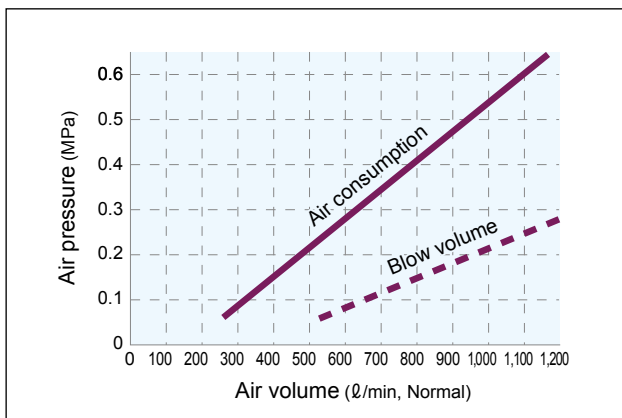

Consumption (l/min, Normal)		
0.1 MPa	0.3 MPa	0.5 MPa
300	605	925